

poteau 60x7

Hauteur panneau mm	Section poteau mm	Longueur poteau mm	Poids module kg/mq
884	≠ 60x7	1200	19,5
1183	≠ 60x7	1500	18,6
1382	≠ 60x7	1750	18,3
1582	≠ 60x7	1950	18,1

## Poteau sur platine plate

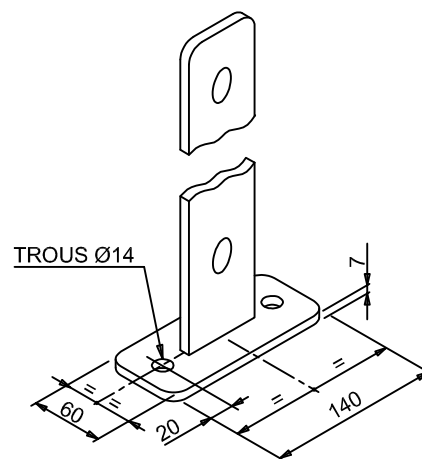
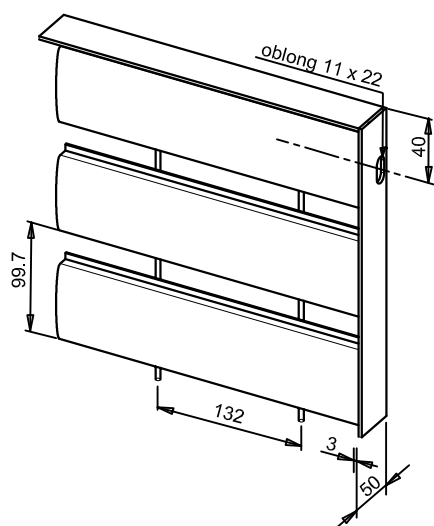
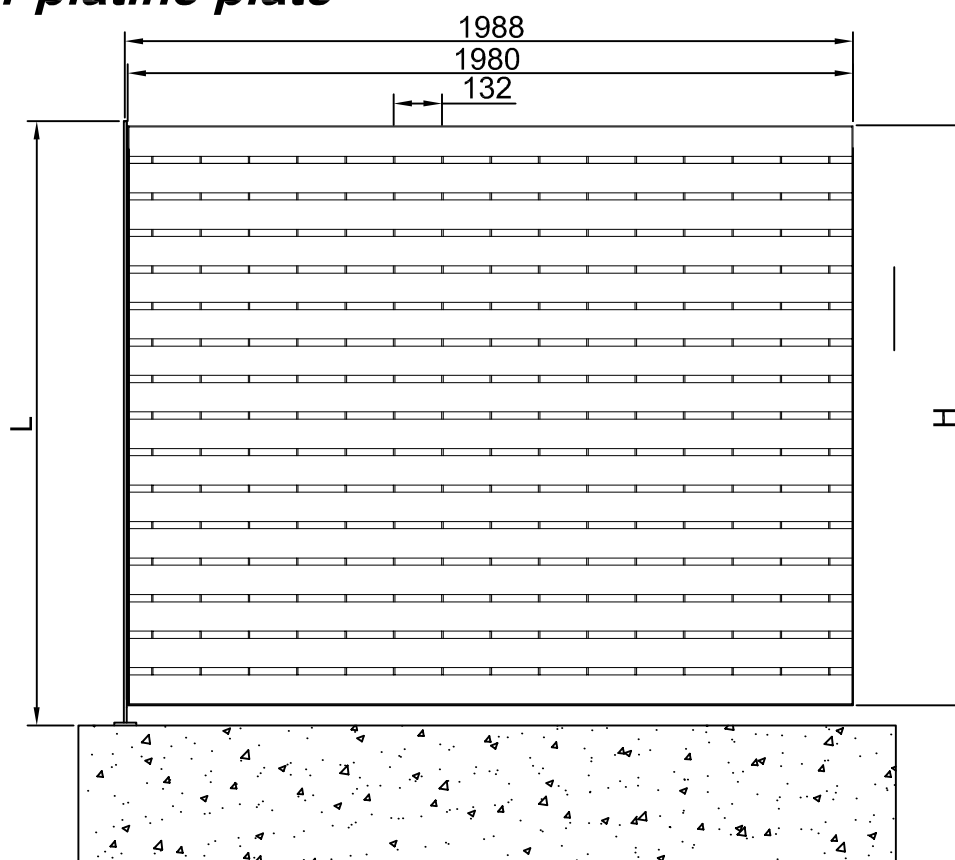

poteau 60x7

Hauteur panneau mm	Section poteau mm	Longueur poteau mm	Poids module kg/mq
884	≠ 60x7	949	19,3
1183	≠ 60x7	1248	18,5
1382	≠ 60x7	1448	18,1
1582	≠ 60x7	1647	17,9