

Hauteur panneau mm	Section poteau mm	Longueur poteau mm	Poids module kg/m ²
930	plat 60x7	1200	12,2
1195	plat 60x7	1465	11,7
1320	plat 60x7	1650	11,6
1460	plat 60x7	1790	11,5
1720	plat 60x7	2085	11,3
1985	plat 60x7	2350	11,1

Matériau: (Fe360B UNI 7070) S235 JR EN 10025

Traitement de surface: Galvanisation à chaud UNI EN ISO 1461

Poteau sur platine plate

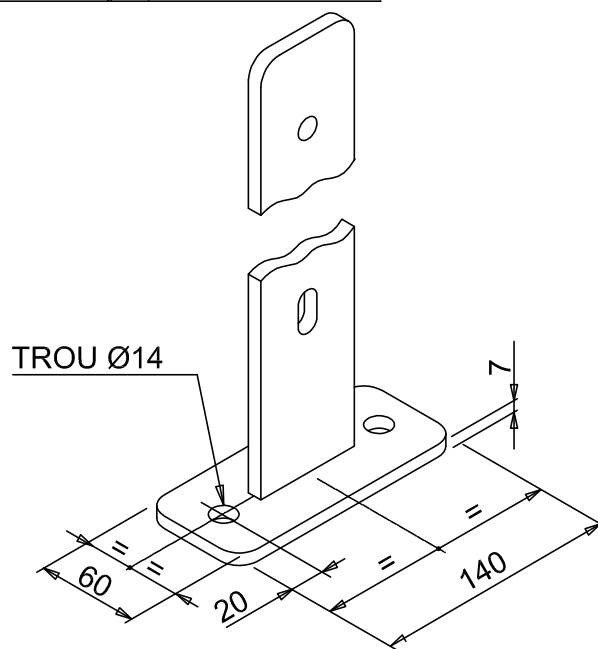
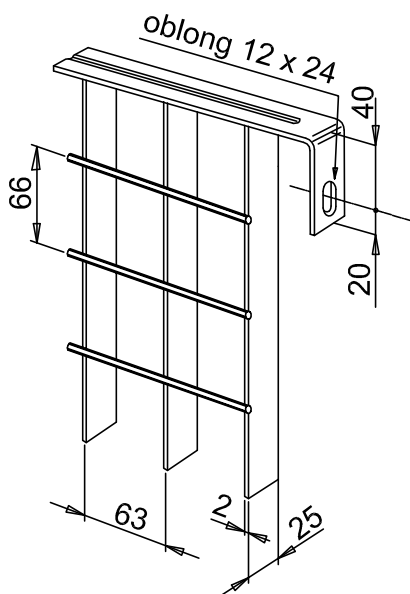
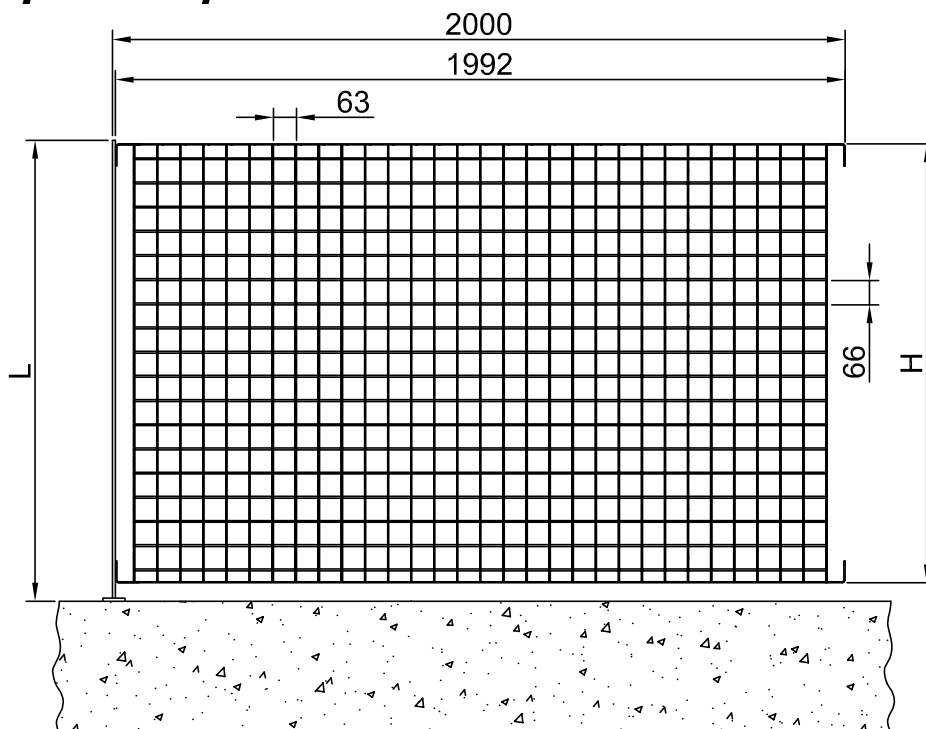

Hauteur panneau mm	Section poteau mm	Longueur poteau mm	Poids module kg/m ²
930	plat 60x7	990	12,1
1195	plat 60x7	1255	11,6
1320	plat 60x7	1380	11,5
1460	plat 60x7	1520	11,3
1720	plat 60x7	1780	11,1
1985	plat 60x7	2045	11,0

Poteau STYLE

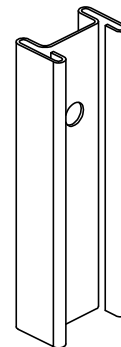
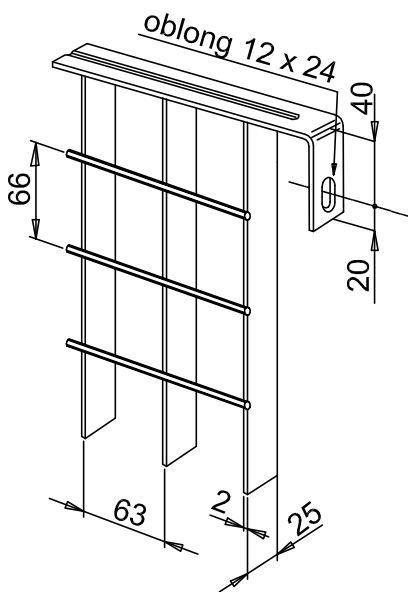
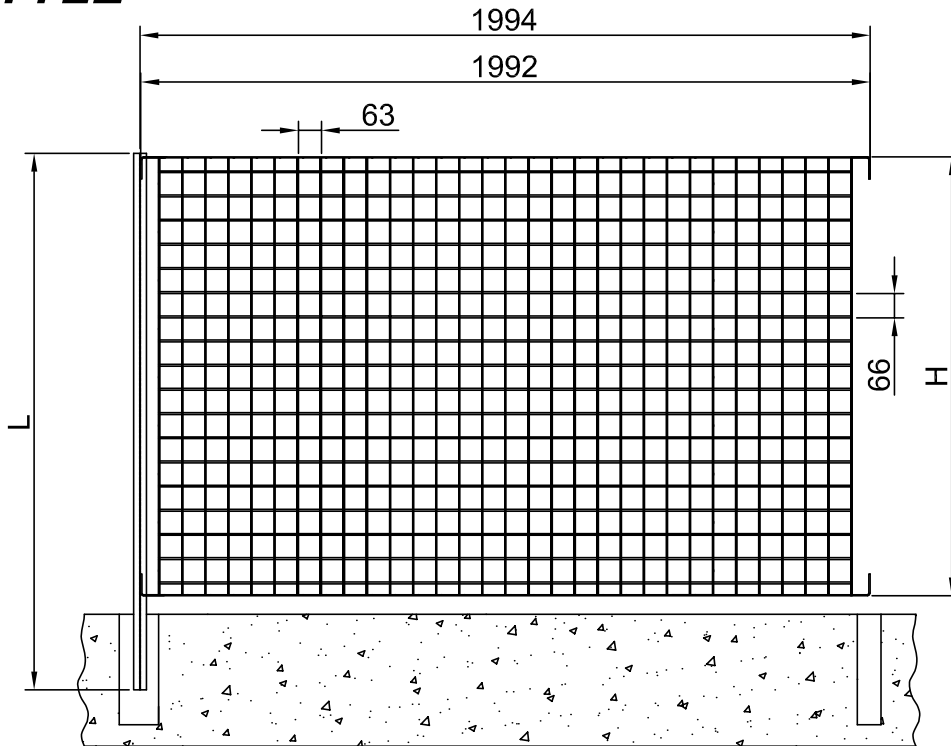

Hauteur panneau mm	Section poteau	Longueur poteau mm	Poids module kg/m ²
930	PROFILE'	1200	11,6
1195	PROFILE'	1465	11,1
1320	PROFILE'	1650	11,1
1460	PROFILE'	1790	10,9
1720	PROFILE'	2085	10,7
1985	PROFILE'	2350	10,6

Poteau STYLE sur platine plate

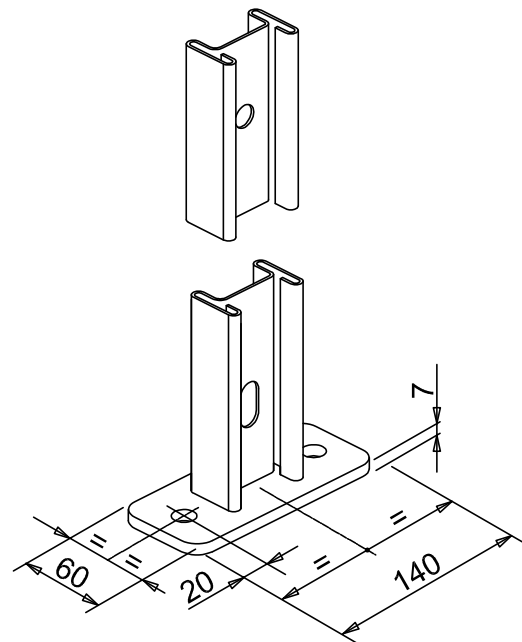
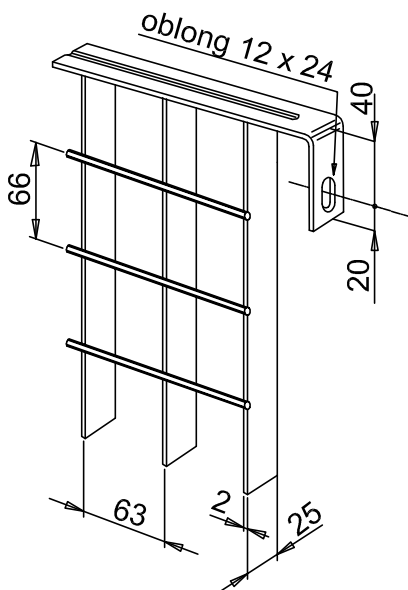
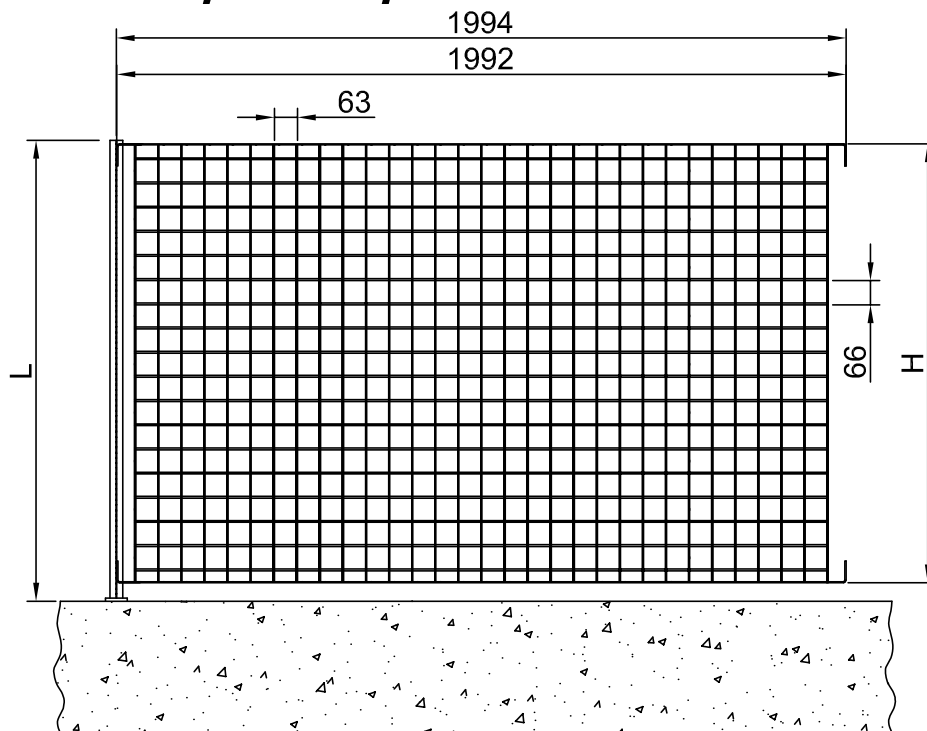

Hauteur panneau mm	Section poteau	Longueur poteau mm	Poids module kg/m ²
930	PROFILE'	990	11,6
1195	PROFILE'	1255	11,1
1320	PROFILE'	1380	11,0
1460	PROFILE'	1520	10,9
1720	PROFILE'	1780	10,6
1985	PROFILE'	2045	10,5