

# Linear Orizzontale

**LIBRA**

## Piantana in piatto ad annegare

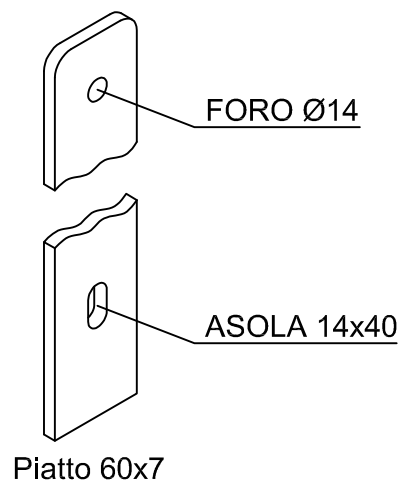
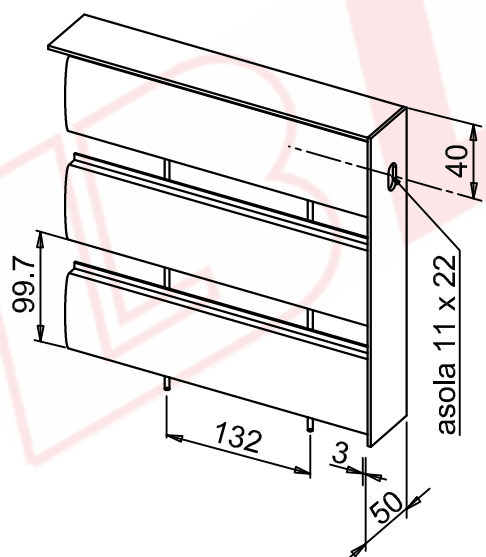
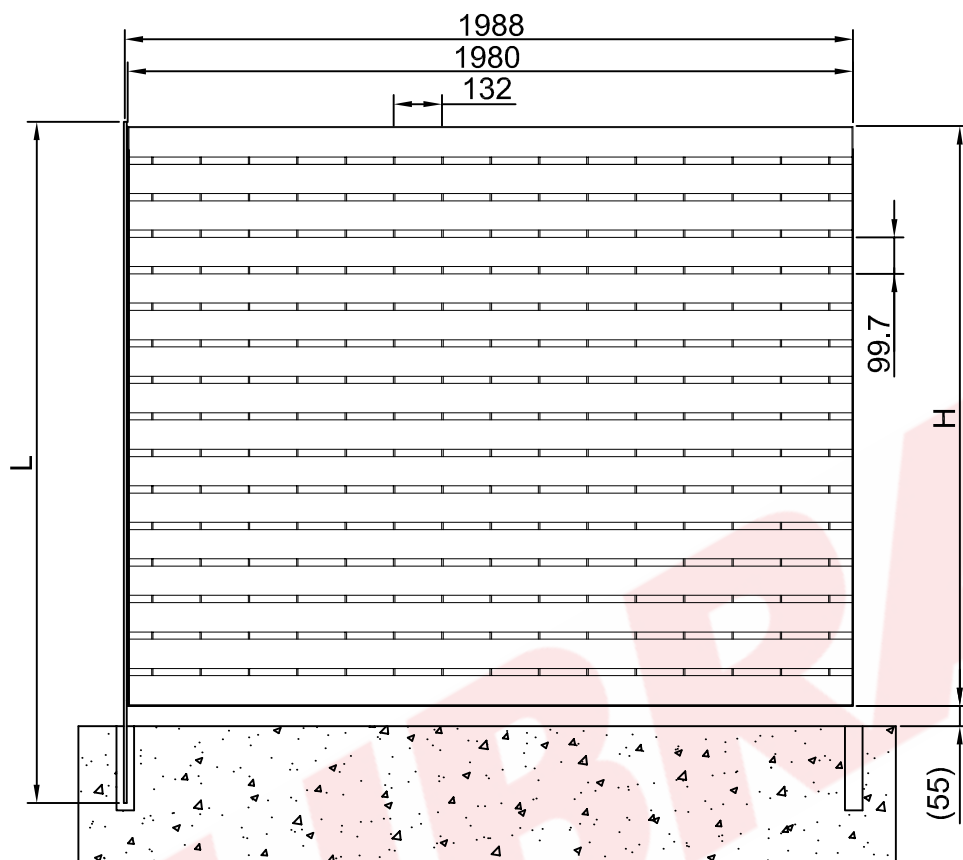

Altezza pannello mm	Peso pannello kg/cad	Tipo piantana mm	Altezza piantana mm	Peso piantana kg/cad
884	29,9	≠ 60x7	1200	4,2
1183	38,4	≠ 60x7	1500	5,2
1382	44,1	≠ 60x7	1750	6,1
1582	49,8	≠ 60x7	1950	6,8

Materiale: S235JR EN 10025

Trattamento superficiale: Zincatura a caldo UNI EN ISO 1461

# Linear Orizzontale

**LIBRA**

## Piantana in piatto con piastra di base

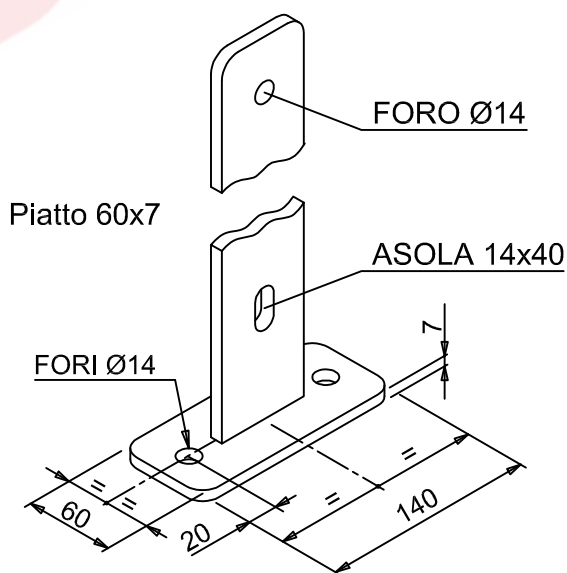
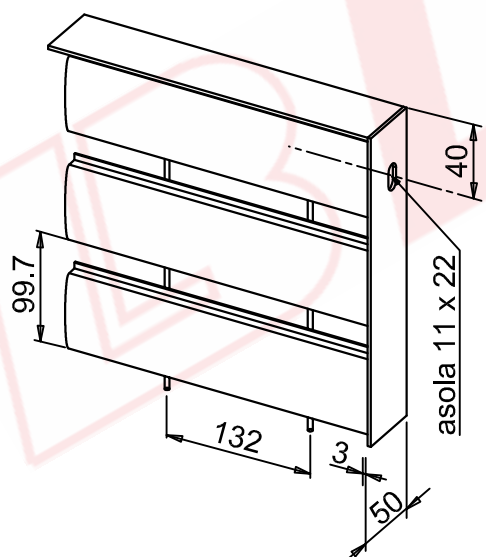
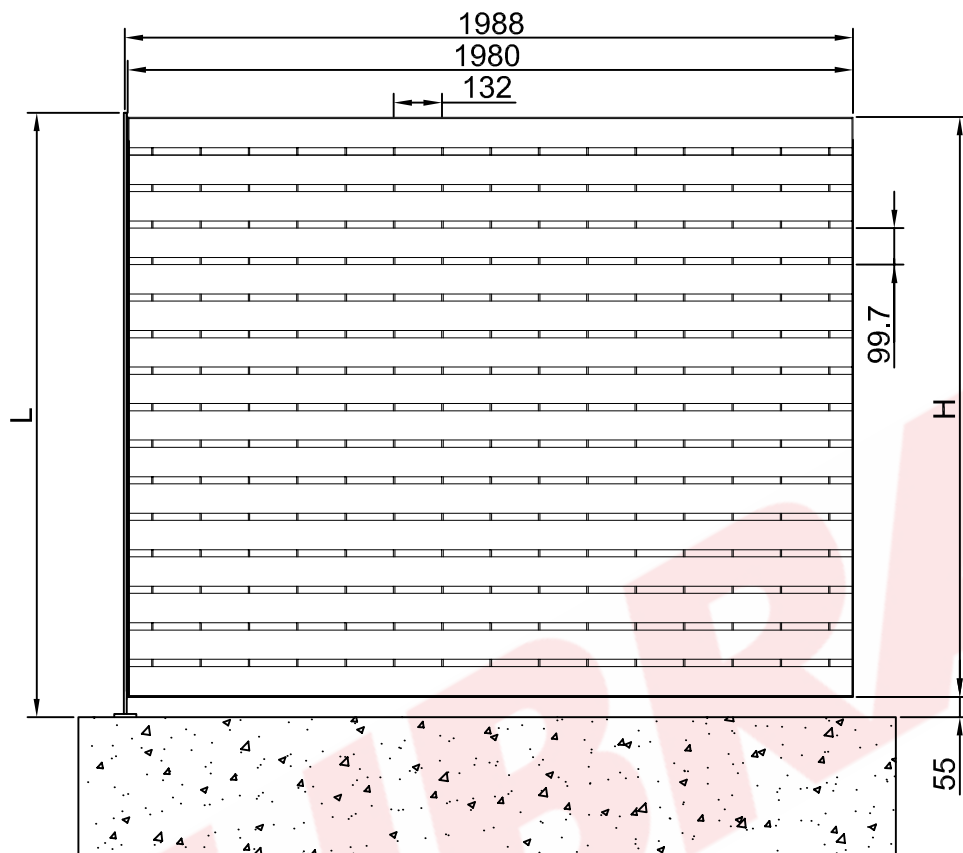

Altezza pannello mm	Peso pannello kg/cad	Tipo piantana mm	Altezza piantana mm	Peso piantana kg/cad
884	29,9	≠ 60x7	949	3,8
1183	38,4	≠ 60x7	1248	4,9
1382	44,1	≠ 60x7	1448	5,5
1582	49,8	≠ 60x7	1647	6,2

Materiale: S235JR EN 10025

Trattamento superficiale: Zincatura a caldo UNI EN ISO 1461