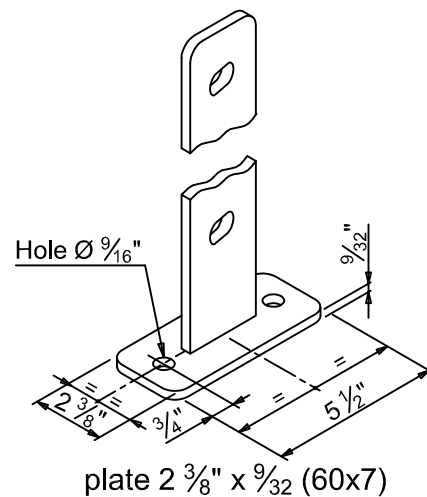
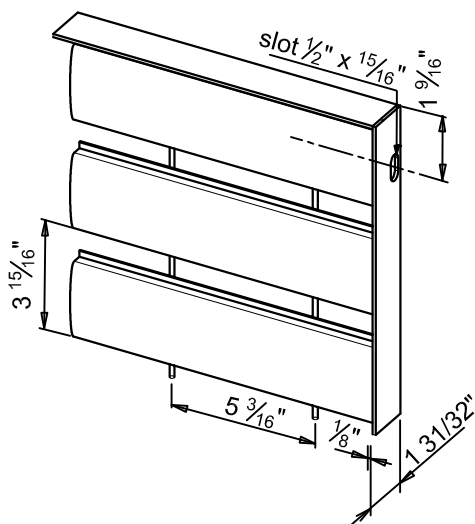
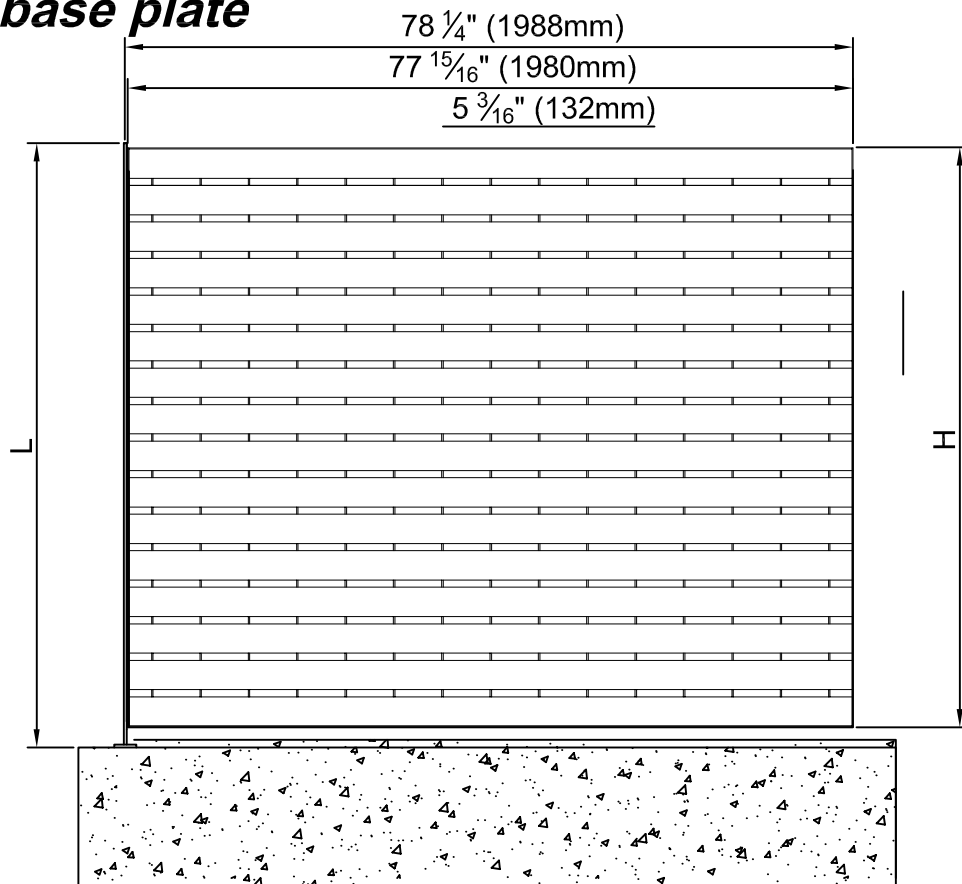

plate $2 \frac{3}{8}'' \times \frac{9}{32}''$ (60x7)

Panel height " (mm)	Post type " (mm)	Post height " (mm)	Module Weight lb/ft ² (kg/m ²)
34 51/64" (884)	2 3/8" x 9/32" (≠60x7)	47 1/4" (1200)	43,0 (19,5)
46 37/64" (1183)	2 3/8" x 9/32" (≠60x7)	59 1/16" (1500)	41,0 (18,6)
54 13/32" (1382)	2 3/8" x 9/32" (≠60x7)	68 57/64" (1750)	40,3 (18,3)
62 9/32" (1582)	2 3/8" x 9/32" (≠60x7)	76 49/64" (1950)	39,9 (18,1)

Post with base plate



Panel height " (mm)	Post type " (mm)	Post height " (mm)	Module Weight lb/ft ² (kg/m ²)
34 51/64" (884)	2 3/8" x 9/32" (≠60x7)	37 23/64" (949)	42,6 (19,3)
46 37/64" (1183)	2 3/8" x 9/32" (≠60x7)	49 9/64" (1248)	40,8 (18,5)
54 13/32" (1382)	2 3/8" x 9/32" (≠60x7)	57 1/64" (1448)	39,9 (18,1)
62 9/32" (1582)	2 3/8" x 9/32" (≠60x7)	64 27/32" (1647)	39,5 (17,9)